

**ESCO**  
SCIENTIFIC



Airstream® RELIANT AR2-4S9 G4

# Airstream® RELIANT G4

## Class II Type A2 Biological Safety Cabinets

*The Leading Energy Efficient, Quiet,  
and Ergonomic Biosafety Cabinet*



# AIRSTREAM® RELIANT G4 (AR2 G4) CLASS II TYPE A2 BIOSAFETY

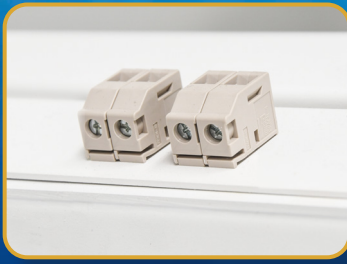

## Zero Volt Relay Contact

- Zero Volt Relay Contact to turn ON/OFF exhaust blower and signal the building alarm

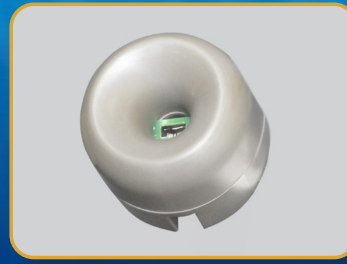

## Airflow Sensor

- Monitors real-time airflow for safety
- Alerts the user if airflow is insufficient



## Rocker Switches and Pressure Gauge

- New and improved controller interface
- Easy to use switches and displays filter loading status
- Manually adjustable UV timer



## Adjustable UV Timer

- Easily adjustable to desired minutes or hours
- Prolongs UV lamp life, for not turning it ON overnight



## One-Piece Interior Wall

- Double layer side walls with negative pressure
- Easy to reach service fixture and outlets
- Large radius corner for easy cleaning



## Raised Arm Rest

- Prevent grille blocking
- Comfortable working posture
- Durable stainless steel construction



Esco Airstream® RELIANT G4 Class II Type A2 Biosafety Cabinet Available in 3 feet, 4 feet, 5 feet, and 6 feet models.



## Ergonomic Work Zone

- 10° angle to optimize user comfort, reduce glare, and maximize reach into the work area
- Brightly illuminated with >1200 lux (111 ft. cd)
- Airtight seal port for cable/tube exit protected by a negative pressure side wall

# CABINET, FEATURING ADVANCED MICROPROCESSOR CONTROLLER



## Energy-efficient DC ECM Blower

- The leading energy efficient Class II Type A2 Biosafety Cabinet in the world with 70% energy savings compared to AC motor
- Stable airflow despite building voltage fluctuations & filter loading
- Standby mode to further reduce power consumption by 60%

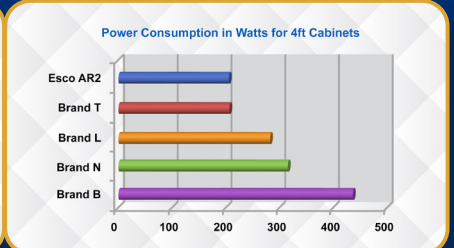
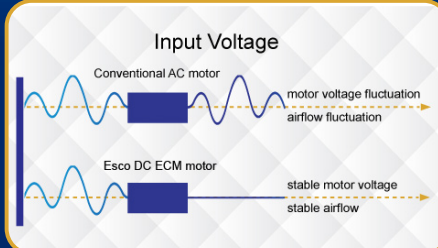

## ULPA Filter

- 10x Filtration efficiency of HEPA filter
- Creates ISO Class 3 work zone instead of industry-standard ISO Class 5
- Same 10 years filter life and replacement cost as HEPA filters

## Dynamic Chamber™

- Blower plenum and side walls are surrounded by negative pressure
- Prevents contaminants from escaping outside
- Steel plenum with Isocide™ coating, instead of flexible bag plenum, to prevent contamination leak

■ Positive pressure  
■ Negative pressure

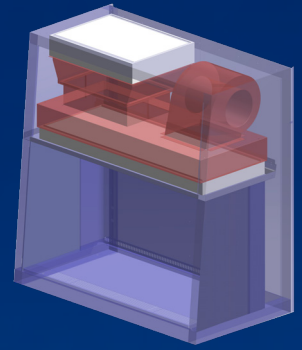

## Angled Sash

- 10° angled front to optimize user comfort, reduce glare and maximize reach into the work area

## User Modified Pass-Through / Cable Port

- 3" Port with 1/4" hole on rubber membrane inside
- NSF-approved. Surrounded by negative pressure
- Allows cables and tubes to exit with fully closed sash

## ISOCIDE™ Powder Coat

- Silver-ion impregnated powder coat
- Inhibits microbial growth to improve safety
- Prevents the plenum from becoming biohazard landfill

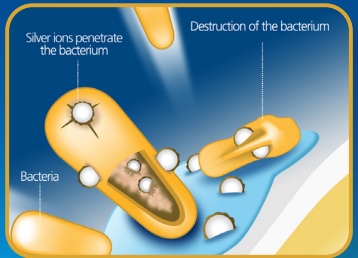

Certification				
	Performance	Air Quality	Filtration	Electrical Safety
Standards Compliance	NSF / ANSI 49, USA	ISO 14644.1, Class 3, Worldwide US Fed Std 209E, Class 1 USA JIS B9920, Class 3, Japan	EN-1822 (H14), Europe IEST-RP-CC001, USA	UL 61010-1 3rd Ed, USA CSA22.2, No.1010-192, Canada

## TECHNICAL SPECIFICATIONS

Model	110-130 VAC, 50/60 Hz	AR2-3S9 G4 2011507	AR2-4S9 G4 2011509	AR2-5S9 G4 2011511	AR2-6S9 G4 2011513
External Dimensions (W x D x H)		1035 x 850 x 1400 mm (40.7" x 33.5" x 55.1")	1340 x 850 x 1400 mm (52.8" x 33.5" x 55.1")	1645 x 850 x 1400 mm (64.8" x 33.5" x 55.1")	1950 x 850 x 1400 mm (76.8" x 33.5" x 55.1")
Gross Internal Dimensions (W x D x H)		915 x 610 x 660 mm (36.0" x 24.0" x 26.0")	1220 x 610 x 660 mm (48.0" x 24.0" x 26.0")	1525 x 610 x 660 mm (60.0" x 24.0" x 26.0")	1830 x 610 x 660 mm (72.0" x 24.0" x 26.0")
Usable Work Area		0.45 m <sup>2</sup> (4.9 ft <sup>2</sup> )	0.6 m <sup>2</sup> (6.5 ft <sup>2</sup> )	0.75 m <sup>2</sup> (8.2 ft <sup>2</sup> )	0.9 m <sup>2</sup> (9.8 ft <sup>2</sup> )
Tested Opening		203 mm (8") or 254 mm (10")			
Working Opening		218 mm (8.6") or 268 mm (10.6")			
Average Inflow Velocity		0.53 m/s (105 fpm)			
Average Downflow Velocity		0.30 m/s (60 fpm)			
Airflow Volume	Inflow / Exhaust Without Ducting	354 cmh (208 cfm)	473 cmh (280 cfm)	591 cmh (348 cfm)	709 cmh (417 cfm)
	Downflow	553 cmh (325 cfm)	738 cmh (434 cfm)	922 cmh (543 cfm)	1107 cmh (652 cfm)
	Required Exhaust with Optional Thimble Exhaust Collar	531 cmh (313 cfm)	710 cmh (418 cfm)	887 cmh (522 cfm)	1064 cmh (626 cfm)
	Static Pressure For Optional Thimble Exhaust Collar	32 Pa / 0.12 in H <sub>2</sub> O	45 Pa / 0.18 in H <sub>2</sub> O	57 Pa / 0.23 in H <sub>2</sub> O	68 Pa / 0.27 in H <sub>2</sub> O
ULPA Filter Typical Efficiency		>99.999% at 0.1 to 0.3 micron, ULPA as per IEST-RP-CC001.3 USA >99.999% at MPPS, H14 as per EN 1822 EU			
Sound Emission per NSF / ANSI 49*		57.5 dBA		58.5 dBA	60.5 dBA
LED Lamp Light Intensity		982 lux (91 foot candles)	1079 lux (100 foot candles)	1040 lux (97 foot candles)	1035 lux (96 foot candles)
Cabinet Construction	Main Body	1.2 mm (0.05") / 18 gauge EG Steel with Isocide™ Oven-Baked Epoxy-Polyester Anti-microbial Powder Coating			
	Work Zone	1.5 mm (0.06") / 16 gauge, Stainless Steel 304, 4B finish			
	Side Walls	1.5 mm (0.06") / 16 gauge, Stainless Steel 304, 4B finish			
	Sash Glass	6 mm UV-absorbing Tempered Glass			
Electrical 110-130 VAC, 50/60 Hz**	Cabinet Full Load Amps (FLA)	11	11.5	12.5	15
	Heat Load (BTU / Hr)	503	628	698	999
	Nominal Power Consumption (W)	160	200	222	318
Net Weight		203 Kg (448 lbs)	245 Kg (540 lbs)	303 Kg (668 lbs)	361 Kg (796 lbs)
Shipping Weight		231 Kg (509 lbs)	300 Kg (661 lbs)	369 Kg (814 lbs)	443 Kg (977 lbs)

Disclaimer: Technical Specifications may be subjected to further changes without further notice.

\*Noise reading in open field condition / anechoic chamber.

Noise reading in normal room varies by room size, layout, and background noise, but may reach roughly 3-4 dBA above these values.

\*\*Electrical power consumption is a measurement of new unit within nominal set point. Result may vary due to several independent variables

### Engineering Drawing

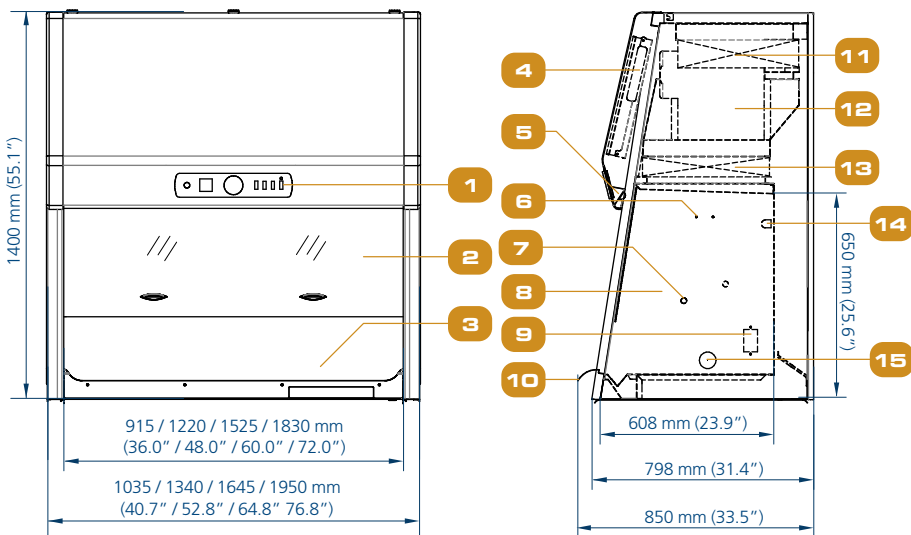

- |   |   |                               |
|---|---|-------------------------------|
| 1. Rocker Switches and Pressure Gauge   | 6. IV Bar Provision (Optional)            | 11. Exhaust ULPA (H14) Filter |
| 2. Tempered Glass - Sliding sash Window | 7. Service Fixture Retrofit Kit Provision | 12. ECM Blower                |
| 3. Stainless Steel Dished Worked Tray   | 8. Stainless Steel Side Wall              | 13. Downflow Filter           |
| 4. Electrical Panel                     | 9. Duplex GFCI Electrical Outlet (5A Max) | 14. UV Lamp                   |
| 5. LED Lamps                            | 10. Stainless Steel Curved Arm Rest       | 15. Cable Port                |

### Common Accessories



Additional SF-2U Service Fixture

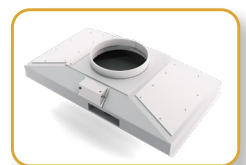

Thimble Exhaust Collar with Alarm

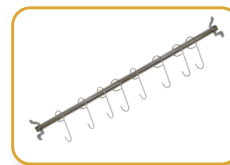

IV Bar



Foot Rest

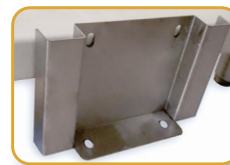

Seismic Bracket



STA Support Stand